

Non rimuovere alcun componente della struttura durante la fase di montaggio  
 Do not remove any component of the frame during assembling  
 Pas enlever aucun composant du châssis pendant l'assemblage

1

Aprire il telaio con l'aiuto di un'altra persona e inserire il perno di blocco.  
 Open the frame with the aid of another person and insert the blocking pin.  
 Ouvrir le châssis avec l'aide d'une autre personne et insérer le pivot bloquant.

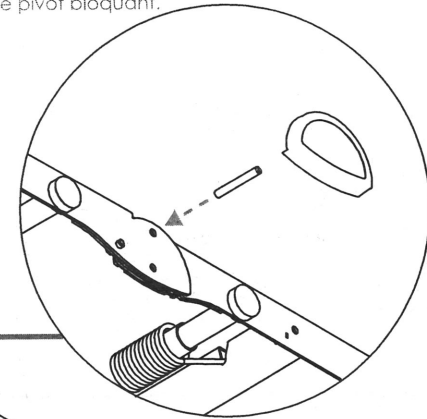
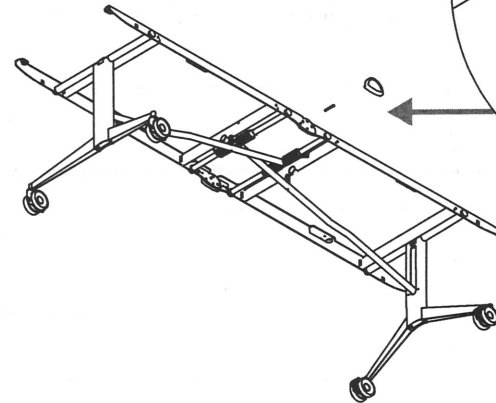
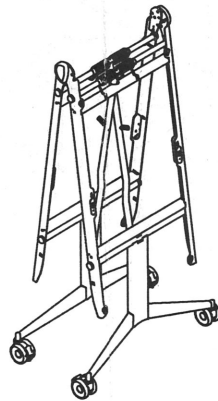

2

Girare il telaio con l'aiuto di un'altra persona e avvitare le 12 viti con rispettive rondelle ai piani.  
 Turn the frame upside-down with the aid of another person and tighten the 12 screws to the table tops.  
 Tourner le châssis à l'envers avec l'aide d'une autre personne et visser les 12 vis sur les plateaux de la table.

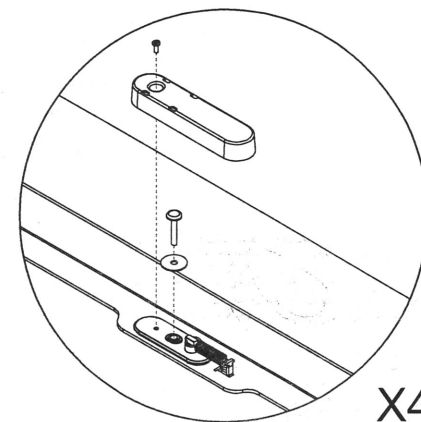
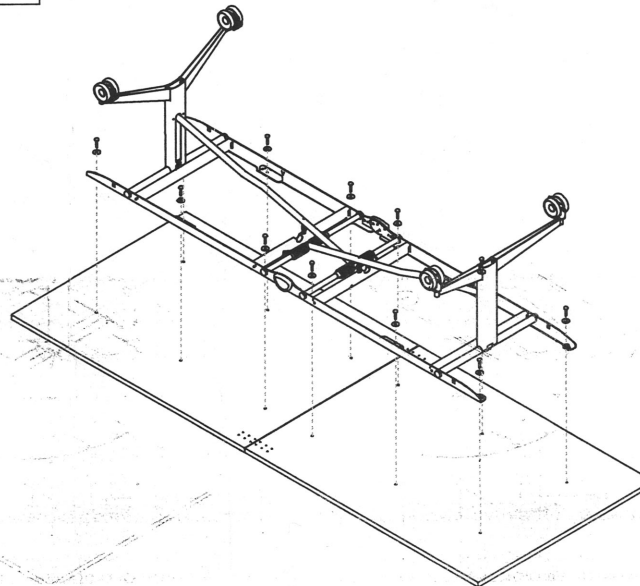

X4

3

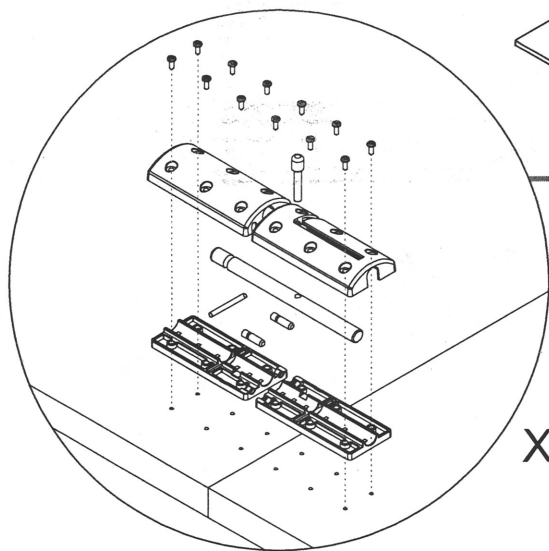

X2

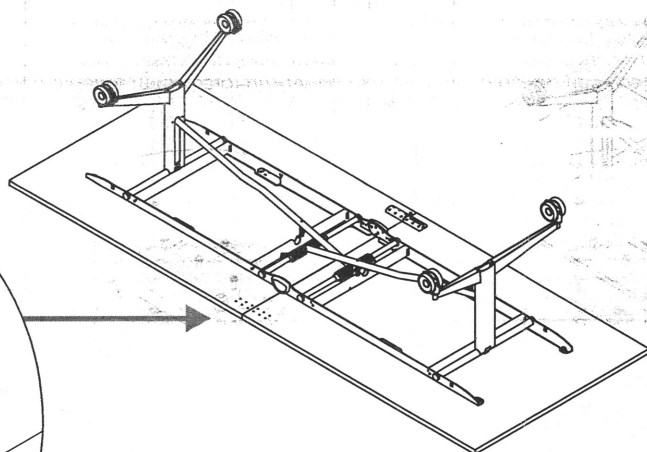

5

Capovolgere il tavolo afferrandolo dai piani. Poi estrarre il perno di blocco.  
 Turn the table in the working position by grabbing it from the tops. Then remove the blocking pin.  
 Retourner la table en la saisissant par les plateaux. Ensuite, extraire le pivot bloquant.

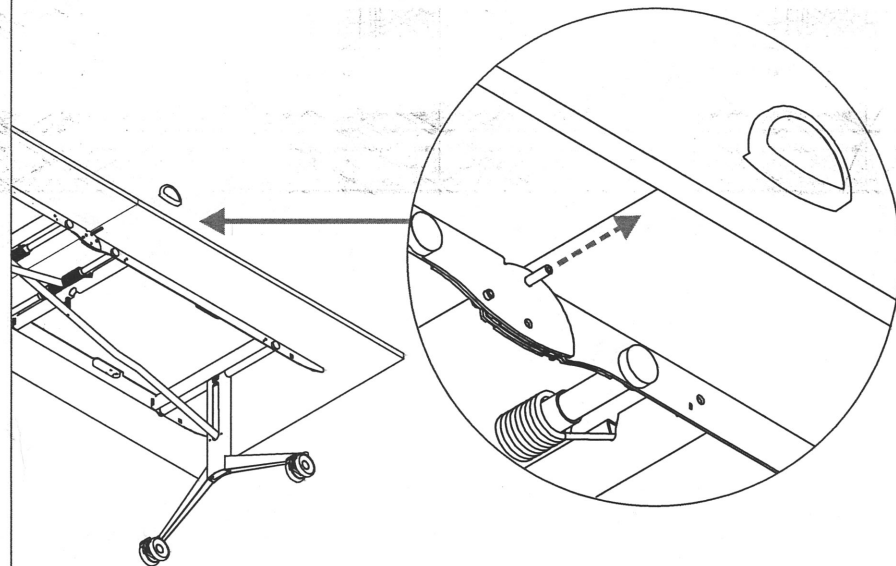

4

Applicare l'etichetta con le istruzioni d'uso.  
 Apply the instructions label.  
 Appliquer l'étiquette avec les instructions d'usage.

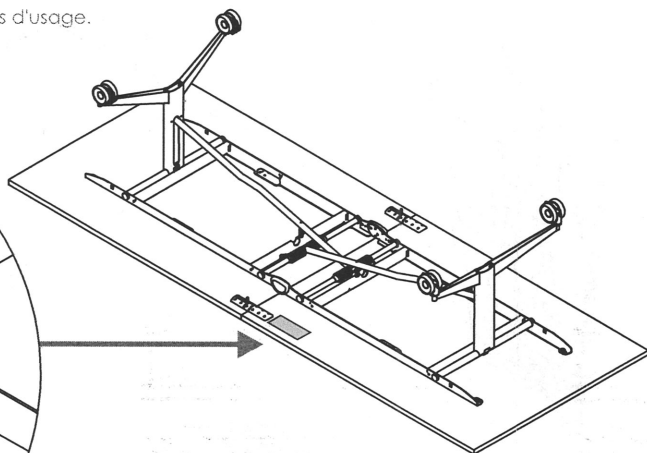
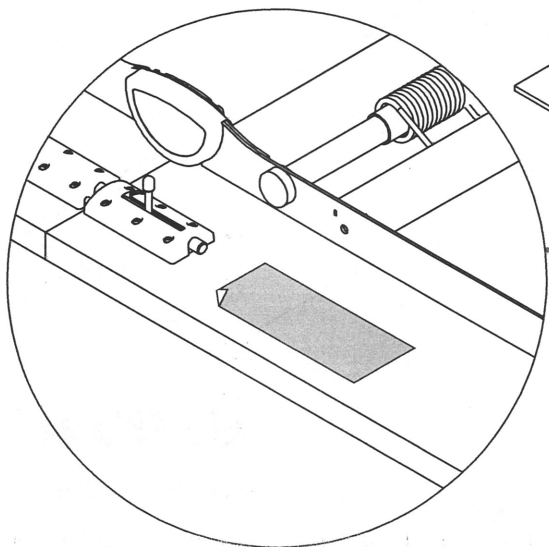

6

Ruotare la vite per regolare la planarità dei piani.  
 Rotate the screw to regulate the top's flatness.  
 Tourner la vis pour régler la planéité des plateaux.

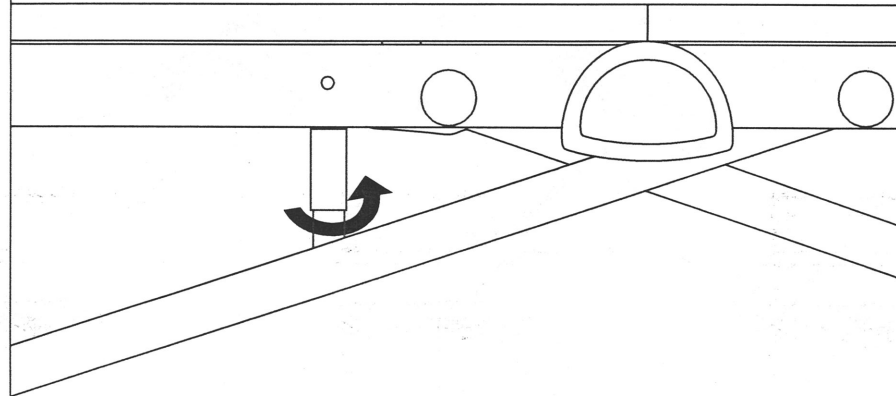

# INSTRUCTION MANUAL

## LIBRO – FOLDING TABLE ON CASTORS

### ART.286

#### 1- GENERAL CONDITIONS

For proper use of the product, carefully refer to the following manual:

Keep the box in which the product is packed away from any heat source as the packaging is made of cardboard.

MARA Srl is not responsible for damages, personal injuries, or any problem if it is caused or related to the incorrect installation and/or use of the product.

Always pay close attention to the presence of moving parts that could cause injuries to things or people.

Always pay attention to the presence of children.

#### List of components included in the product box:

- 1 table frame
- 2 sets of lock latches
- 12 screws + 12 washers for assembling of the top to the frame +  
4 screws + 4 plastic cover for anti-shock spring +  
24 wood screws for assembling of the lock latches to the table tops
- 1 assembly instruction + 1 blocking pin and 1 instruction use sticker

#### 2- PRIOR TO EVERY USE

Always check the state of wear of the product in order to ensure complete safety for things and people. Check the correct assembly of the product.

#### 3- METHOD OF USE

##### TO OPEN THE TABLE

Check there are no obstacles around the table and enough space to open it.

The user must stand next to the closed table, facing the tops in symmetrical position

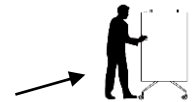

The user must carefully hold the table tops and slowly distance them, helping the table to open.

While the table opens, the user must guide and hold the table tops with his hands.

When the table is completely opened, the user must lock the latches placed under the table tops.

When the table is in the operative position, the user must lock the 4 castors.

##### TO CLOSE THE TABLE

Check there are no obstacles below the table.

The user must unlock the 4 castors.

The user must unlock the lock latches placed under the table tops.

The user must stand next to the table, facing the point where the tops meet.

The user must open his arms and lift the tops, guiding and moving them closer towards the vertical position.

The pre-charged spring helps the user in this movement and automatically stops the table at the end of the movement in the closed position.

For ASSEMBLY INSTRUCTION and INSTRUCTION USE refer to the related manual and sticker included in the product box. The ASSEMBLY INSTRUCTION manual and the INSTRUCTION USER sticker are integral part of this manual.

The product is not suitable for outdoor use.

See next page



#### 4- MAINTENANCE

The product is carefully verified at the moment of the packing.  
We suggest to complete a security check at least every month to verify the correct suitability for use of your product.

#### 5- CLEANING

Clean using only a damp cloth and neutral soap. Dry thoroughly before use. Use water at a temperature not exceeding 30°C. Do not use water jet or steam washing machines.  
Never use acids, alkalines or solvents such as acetone or diluent.

#### 6- TECHNICAL CHARACTERISTICS

##### Materials and components:

Frame of mild steel tube and mild steel sheet. MIG and TIG welding.  
Powder coated or chromed components.  
PP covers and bungs.  
Galvanized screws and washers

#### 7- WARRANTY

The product is warranted against defects in materials or production for a period of two (2) years from the invoice date, considering exclusions and limitations as specified below.  
This warranty is not valid in case of misuse, abuse or modification of the product and failure to follow the indicated instructions. MARA Srl is not responsible for damages, personal injuries, or any problem if it is caused or related to the incorrect installation and/or use of the product.  
The product is not guaranteed against damage or defects in the following conditions: natural disasters, incorrect maintenance or repair, use of improper parts or components not supplied by MARA Srl, lack of adherence to guidelines and use instructions, unauthorized modification, shipping damages, or from failure to instructions indicated in the manual.  
Any damage due to normal use of the product is not covered by guarantee.

#### 8- REPAIRS

##### Warranty Repair

In case of defects or damages during the warranty period, MARA Srl evaluates with the customer if the product defect is covered by warranty. MARA Srl, in its sole discretion, may replace or repair the product under warranty shipped by the client to our head office. The labor costs related to repair of the product can be borne by MARA Srl if it is determined that the repair is under warranty. A repair or replacement does not renew or extend the warranty.

##### Repair of a product not covered by warranty

A product not covered by warranty can be repaired or replaced only after receiving prior authorization from MARA Srl. The labor and shipping costs related to repair or replacement not covered by the warranty will be fully borne by the customer.

##### Non-defective products

The customer will be notified if, after examining a returned product, MARA Srl verifies that the product is not defective. The product will be returned to the customer and will be liable to pay the return shipping costs.

#### 9- DISCLAIMERS

Except for conditions stated in this document and within legal limits, MARA Srl does not offer any other warranty or further condition.

The duration of any warranty that may be imposed by law is limited to the warranty period indicated in this document. This guarantee is subject to change without prior notice.