

INSTALLATION INSTRUCTIONS: A-Frame Table

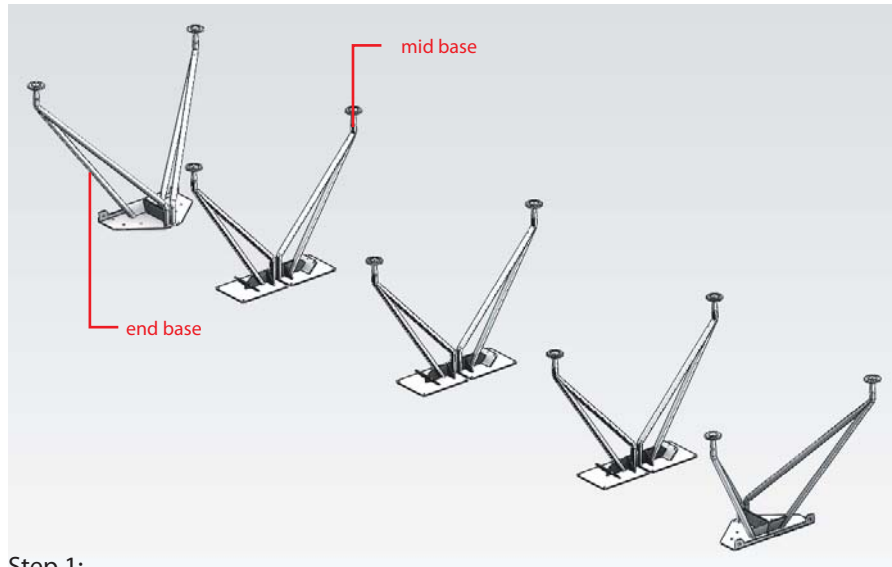

Step 1:
Unpack all bases and place upside down on floor roughly in the position they will be attached to rail.

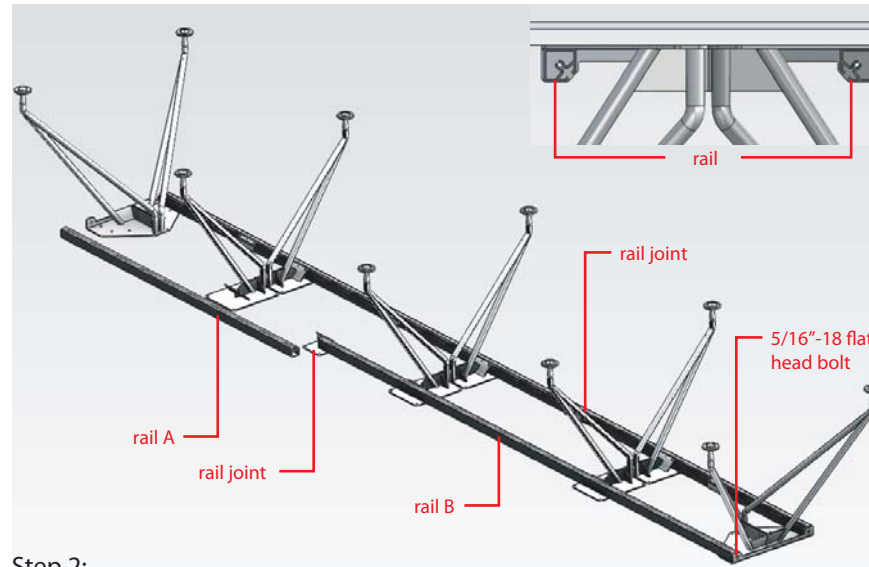

Step 2:
Locate rails and place on base plates with groove facing inward. If you have a multi-rail assembly be sure the rail grooves are both facing inward and the joint is staggered. Secure rail to End bases with 5/16" x 1" FH-bolt. Secure the rail joint with bolts and rail spacer bracket (see detail). Secure mid bases to rail with 1/4"-20 x 9/16 joiner bolts inserted in t-slot nut pre-installed in rail (see detail).

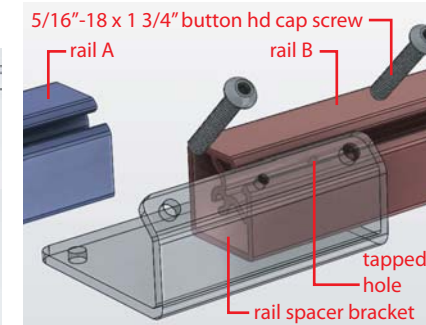

Rail Joint Detail

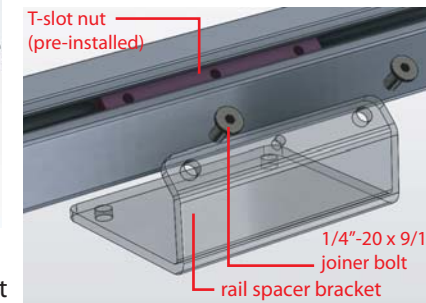

Rail Spacer Bracket / Mid Base Attachment Detail

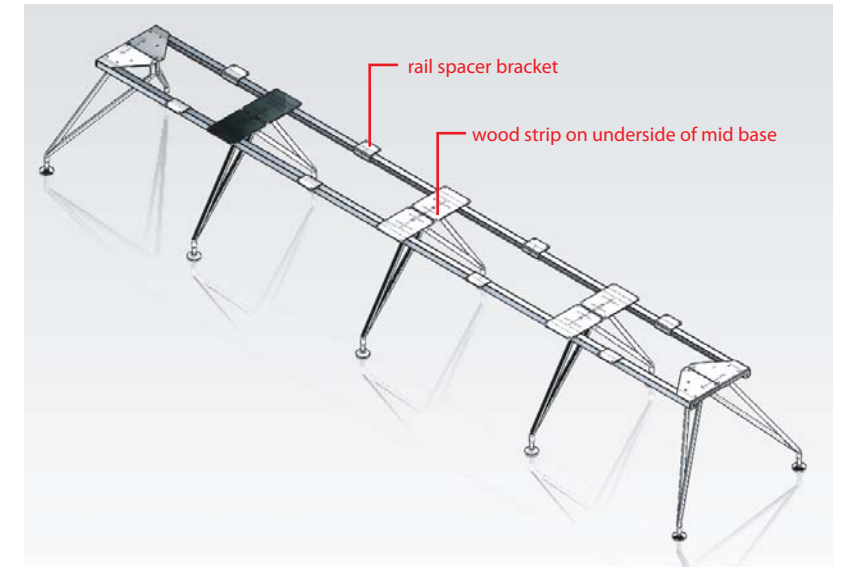

Step 3:
With a minimum of 2 people rotate the assembly... Being careful the rail does not separate too much in center. For large assemblies the mid bases are shipped with wood strips that hold the bases and rails together to aid in this rotation... These can be removed once the structure has been flipped. Install rail spacer bracket with joiner bolts and t-slot nuts pre-installed in rail (see detail).

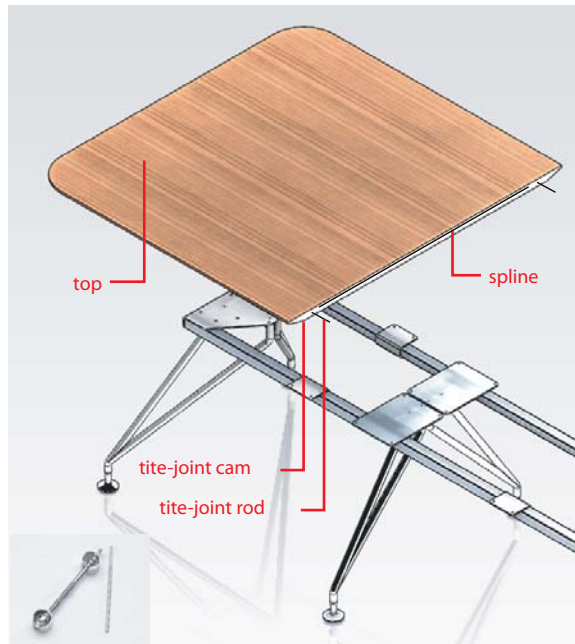

Step 4:
Set end piece of top in place aligning threaded inserts in underside of top with through holes in end base. Secure with 1/4"-20 x 7/8" joiner bolts. Insert cam portion of tite-joint fastener into counter bore on underside of top. The tite-joint threaded portion and spline are inserted in end grain of top. Slide next section of top carefully in place. Top sections are numbered... Be sure to use correct numerical sections in order to have grain align properly. Slip tite-joint ring into place in open underside counter bore and tighten cam with tite-joint rod (provided). Align top inserts with rail spacer brackets and bases secure with 1/4"-20 x 9/16" joiner bolts. Repeat for all top sections.

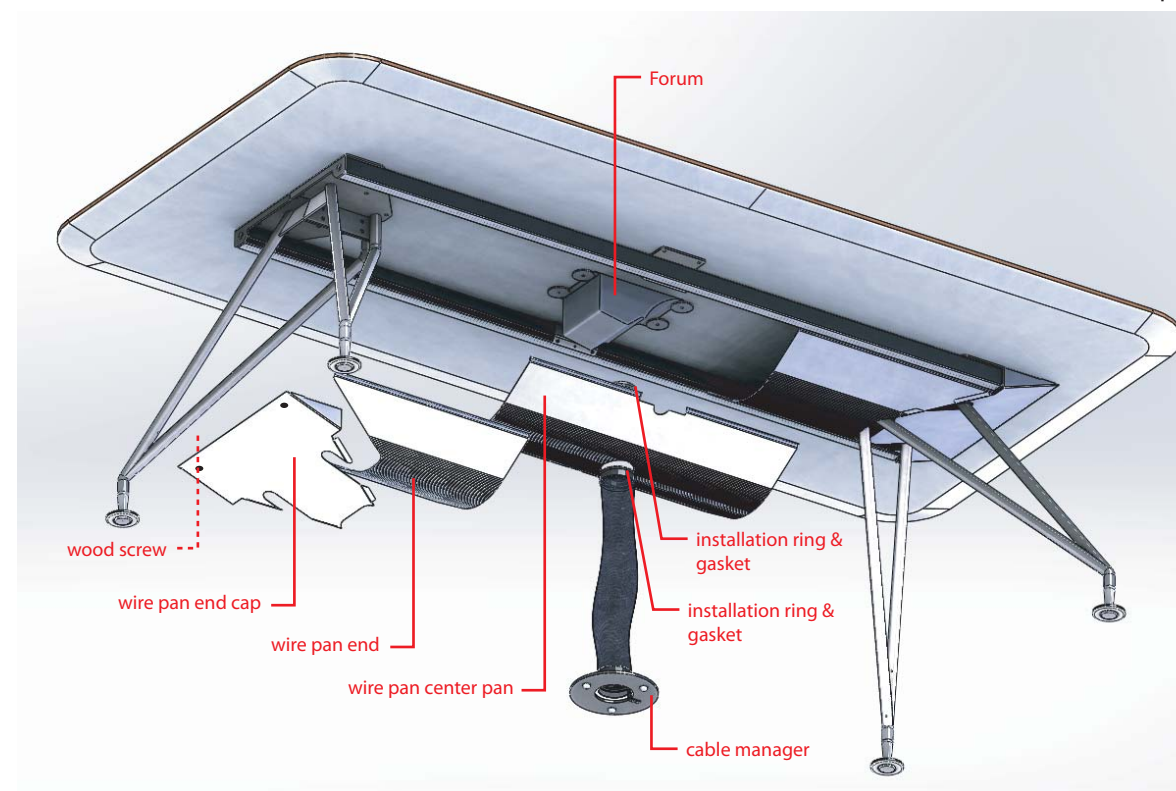

Step 5:
If your table has Forums:
Install the Forum units as per assembly instructions included with the unit.
To install the wire management directly to the bottom of table, place in desired location and secure with #6 x 5/8" wood screws provided. Wires can be managed with plastic clips that clip into rail or self adhesive strips. Direct cables to wire manager and down to floor.

If your installation includes a wire pan:
Install Forum unit as above then install wire manager into mid pan with included threaded rings and spacer gasket. End caps are installed by using #6 x 5/8" wood screws inserted in pilot holes in underside of top. Next install wire pan ends by squeezing and aligning with groove in rail...slide down towards end cap. Finally feed all wires into the cable manager and squeeze part, align with groove in rail. Part will flex into place locking the location.